

### Description

The NuVent SS Series fan-lights offer exceptionally quiet performance in a sturdy galvanized steel housing. All S Series models feature an exclusive curved grille design for contemporary style, making it an attractive option for bathroom and general ventilation applications where low noise levels are required. The SS90FL performance is specifically designed to provide high flow at .25" w.g. static pressure.

### Features

#### Grille

- Attractive curved styling with soft rounded profiles.
- Textured, white polymeric.
- Mounts directly to housing with torsion springs.

#### Housing

- Heavy 22-gauge galvanized steel construction.
- Extended discharge collar for easy attachment to 4" diameter duct.
- Mounts with adjustable hanger bars (included).
- Top and side electrical knockouts for easy access.
- Large removable wiring compartment.

#### Blower

- Built-in backdraft damper.
- Removable blower with easy slide-in mounting.
- Resiliently mounted motor for quiet operation.
- Plug in motor rated for 120 volts 60 Hz operation.

#### Light

- Energy efficient 21-watt 2-D style fluorescent bulb.
- Bright 1350 lumen output.

#### Other

- This product is approved for use over tub/shower enclosures when installed in a GFI protected branch circuit.
- Permanently lubricated ball bearing, shaded pole motor.
- Dual inlet, forward curved blower wheel

### Performance

- Air Delivery: 80cfm @ .25"w.g. s.p.  
100cfm @ .1"w.g.s.p.
- Sound Level - 1.5 sones
- Volts - 120
- Hertz - 60
- Amps - 1.2
- Watts - 83 (fan only)
- Duct - 4" round
- Lamp - G.E. 2-D 21-watt fluorescent

The Home Ventilating Institute has tested and certified the airflow performance (CFM) and sound levels (sones) of this product.

### General

This product has been evaluated by Underwriters Laboratories and conforms to both UL and CSA safety standards.



### Specifications

NuVent ventilator model NXSS90FL. The fan-light shall be constructed with a galvanized steel housing including adjustable hanger bar mounting and 4" diameter discharge collar. The blower unit shall be removable with a permanently lubricated, ball bearing, plug-in motor. Air delivery and sound levels shall be certified by HVI at the levels listed for this model. All units shall be UL listed.

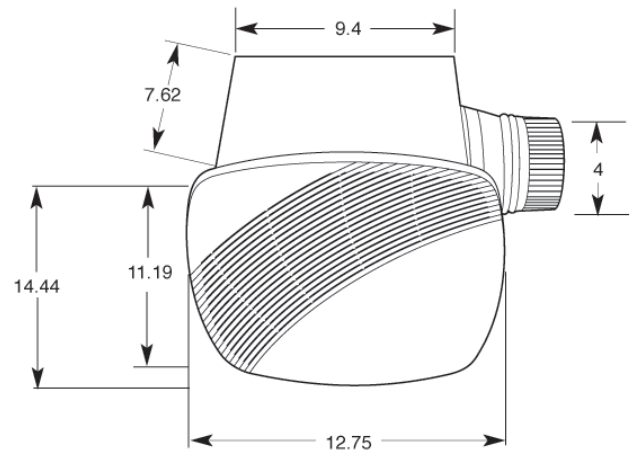

NuVent Product Performance  
Model NXSS90FL

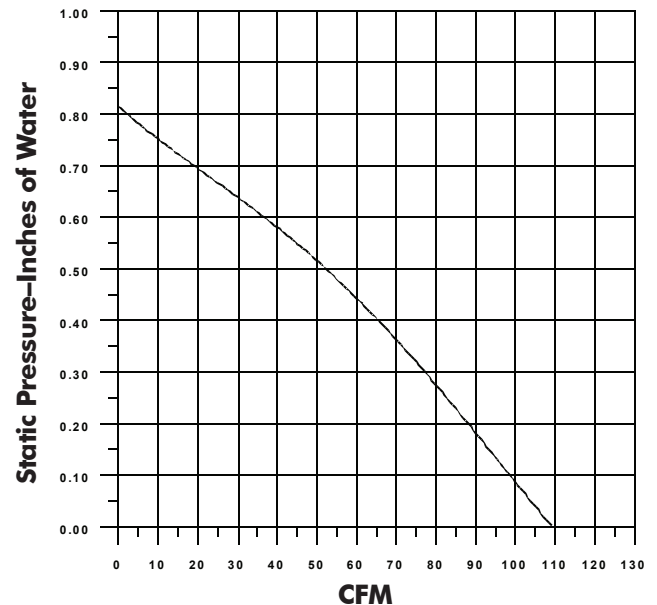

SPECIFICATION			PROJECT:
Reference	Quantity	Comments	Location:
			Architect:
			Engineer:
			Contractor:
			Submitted by:
			Date: